

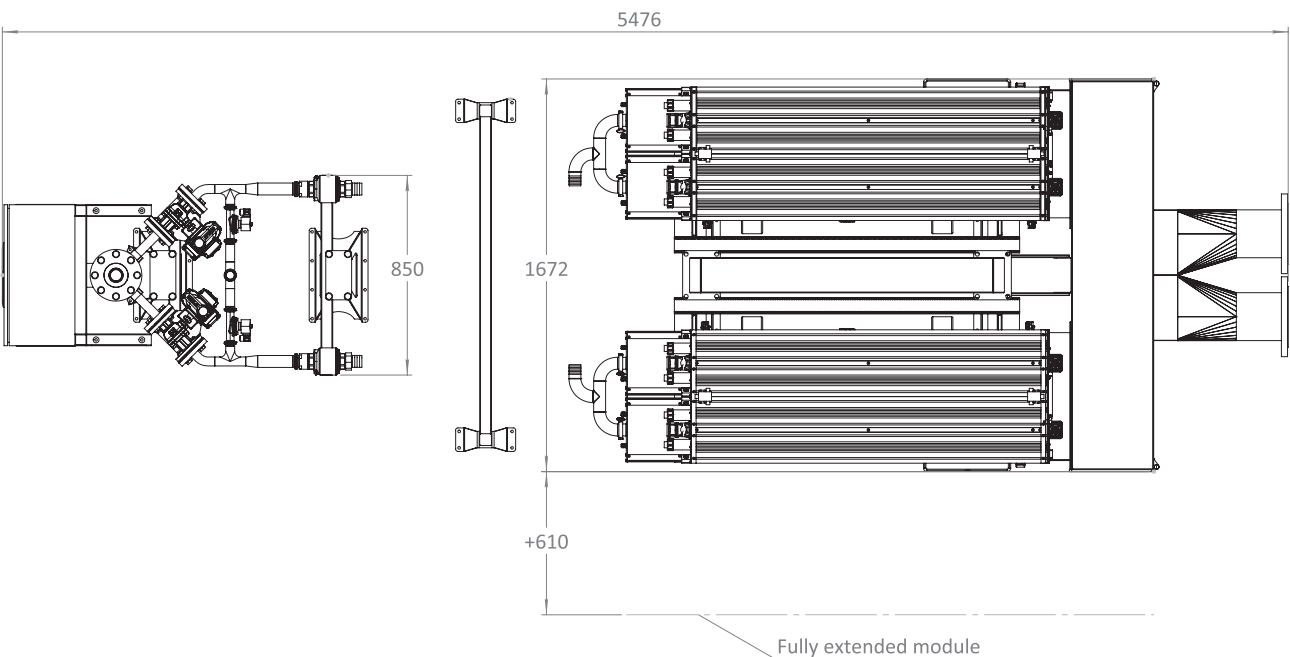

# Technical Data & System Specifications

*NovoLabs™ modular Supercritical UV™* disinfection systems — for Ultra Low UVT applications

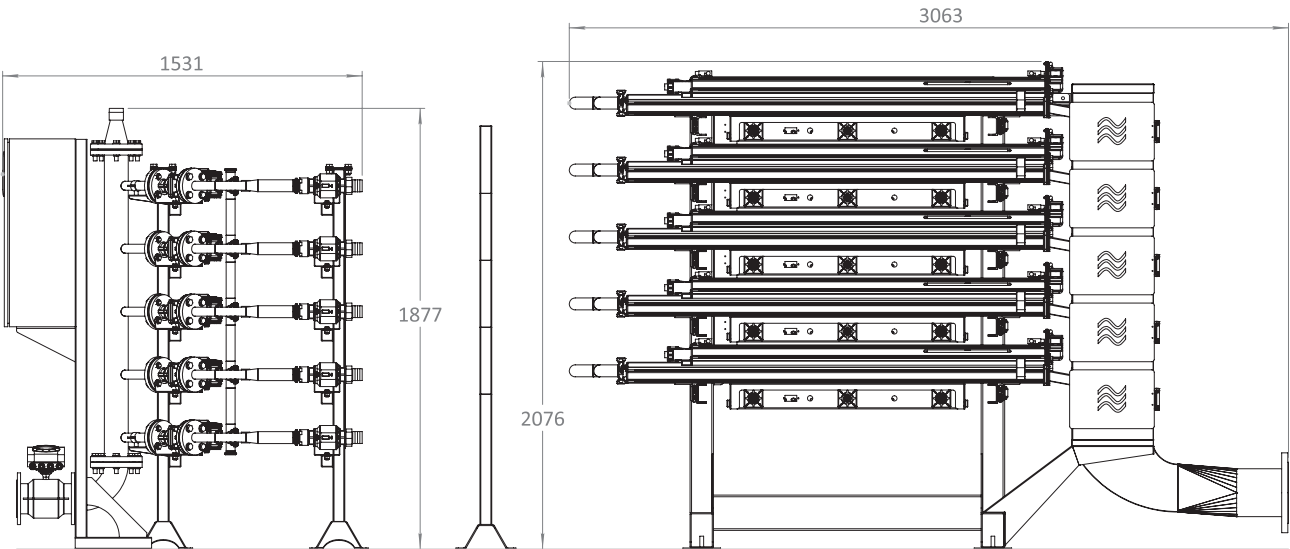

Model	SCUV™ 400	SCUV™ 800	SCUV™ 1200	SCUV™ 1600	SCUV™ 2000	SCUV™ 2400	SCUV™ 3200	SCUV™ 4000
No. of SCUV™ Treatment Modules	1	2	3	4	5	6	8	10
Max Flow Rate Capacity m <sup>3</sup> /day*	570	1140	1700	2280	2880	3450	4600	5700
Max Flow Rate Capacity m <sup>3</sup> /hr*	24	48	72	96	120	144	192	240
Max Flow Rate Capacity L/s*	6.7	13.3	20.0	26.7	33.3	40.0	53.3	66.7
Max Flow Rate Capacity Usg/min	106	211	317	423	529	634	845	1057
* Note: Maximum flow rate differs for each application and lower throughput rates may be required for difficult-to-treat liquids.								
<b>Lamps &amp; Lamp Monitoring</b>								
Number of Ultraviolet Lamps	2	4	6	8	10	12	16	20
Max. Lamp Power (Combined) W.	520	1040	1560	2080	2600	3120	4160	5200
Ultraviolet Lamp	High Output, Low-pressure Amalgam	High Output, Low-pressure Amalgam	High Output, Low-pressure Amalgam	High Output, Low-pressure Amalgam	High Output, Low-pressure Amalgam	High Output, Low-pressure Amalgam	High Output, Low-pressure Amalgam	High Output, Low-pressure Amalgam
Energy Consumption (J/L) at max. flow rate.	78	78	78	78	78	78	78	78
<b>Standard Features &amp; Inclusions</b>								
Individual Lamp Monitoring	Yes	Yes	Yes	Yes	Yes	Yes	Yes	Yes
Lamp Temperature Control	Optional	Optional	Optional	Optional	Optional	Optional	Optional	Optional
Parallel Processing	Optional	Yes	Yes	Yes	Yes	Yes	Yes	Yes
Automatic Flowrate Management	Yes	Yes	Yes	Yes	Yes	Yes	Yes	Yes
Ultraviolet Intensity Sensor	Optional	Optional	Optional	Optional	Optional	Optional	Optional	Optional
Automated Flush System	Recommended	Recommended	Recommended	Recommended	Recommended	Recommended	Recommended	Recommended
Automated Lamp-Out Alarm	Yes	Yes	Yes	Yes	Yes	Yes	Yes	Yes
Automated Lamp-Out Switch-Over	Optional	Yes	Yes	Yes	Yes	Yes	Yes	Yes
Valve & Flow Meter Monitoring	Yes	Yes	Yes	Yes	Yes	Yes	Yes	Yes
Lamp Life-Time Hours	Yes	Yes	Yes	Yes	Yes	Yes	Yes	Yes
Lamp/status indicator LED	Yes	Yes	Yes	Yes	Yes	Yes	Yes	Yes
Safety cut out switch	Yes	Yes	Yes	Yes	Yes	Yes	Yes	Yes
Stainless Steel inlets and outlet	Yes	Yes	Yes	Yes	Yes	Yes	Yes	Yes
User interface touch screen	Optional	Optional	Optional	Optional	Yes	Yes	Yes	Yes
Control System	Embedded PC	Embedded PC	Embedded PC	Embedded PC	PLC	PLC	PLC	PLC
4G SIM Remote Monitoring	Yes	Yes	Yes	Yes	Yes	Yes	Yes	Yes
Continuous Monitoring Camera	Optional	Optional	Optional	Optional	Optional	Optional	Optional	Optional
Containerised Housing	Optional	Optional	Optional	Optional	Optional	Optional	Optional	Optional
Air Conditioning Unit	As Required	As Required	As Required	As Required	As Required	As Required	As Required	As Required
<b>Operating Requirements</b>								
Power Supply Requirements	1-PH, 10A	1-PH, 10A	3-PH, 16A	3-PH, 16A	3-PH, 20A	3-PH, 20A	3-PH, 32A	3-PH, 32A
	Excludes power allowance for air-conditioning				Includes power allowance for air-conditioning			
Max. Operating Pressure (Bar)	7.5 Bar	7.5 Bar	7.5 Bar	7.5 Bar	7.5 Bar	7.5 Bar	7.5 Bar	7.5 Bar
Min. Operating Pressure (Bar)	0.5 Bar	0.5 Bar	0.5 Bar	1 Bar	1 Bar	1 Bar	1 Bar	1 Bar
Max. Particulate Size (micron)*	1000	1000	1000	1000	1000	1000	1000	1000
pH Range	**	**	**	**	**	**	**	**
Max. Liquid Viscosity	***	***	***	***	***	***	***	***

\* larger particle throughput possible on request (subject to treatment goals)

\*\* Contact *NovoLabs™* to discuss liquids that are not neutral

\*\*\* Contact *NovoLabs™* to discuss any highly viscous liquids requiring treatment

Model	SCUV™ 400 Plus	SCUV™ 800 Plus	SCUV™ 1200 Plus	SCUV™ 1600 Plus	SCUV™ 2000 Plus	SCUV™ 2400 Plus	SCUV™ 3200 Plus	SCUV™ 4000 Plus
No. of SCUV™ Treatment Modules	1	2	3	4	5	6	8	10
Max Flow Rate Capacity m <sup>3</sup> /day*	570	1140	1700	2280	2880	3420	4600	5700
Max Flow Rate Capacity m <sup>3</sup> /hr*	24	48	72	96	120	144	192	240
Max Flow Rate Capacity L/s*	6.7	13.3	20.0	26.7	33.3	40.0	53.3	66.7
Max Flow Rate Capacity Usg/min	106	211	317	423	529	634	845	1057
* Note: Maximum flow rate differs for each application and lower throughput rates may be required for difficult-to-treat liquids.								
<b>Lamps &amp; Lamp Monitoring</b>								
Number of Ultraviolet Lamps	4	8	12	16	20	24	32	40
Max. Lamp Power (Combined) W.	1040	2080	3120	4160	5200	6240	8320	10400
Ultraviolet Lamp	High Output, Low-pressure Amalgam	High Output, Low-pressure Amalgam	High Output, Low-pressure Amalgam	High Output, Low-pressure Amalgam	High Output, Low-pressure Amalgam	High Output, Low-pressure Amalgam	High Output, Low-pressure Amalgam	High Output, Low-pressure Amalgam
Energy Consumption (J/L) at max. flow rate.	156	156	156	156	156	156	156	156
<b>Standard Features &amp; Inclusions</b>								
Individual Lamp Monitoring	Yes	Yes	Yes	Yes	Yes	Yes	Yes	Yes
Lamp Temperature Control	Optional	Optional	Optional	Optional	Optional	Optional	Optional	Optional
Parallel Processing	Optional	Yes	Yes	Yes	Yes	Yes	Yes	Yes
Automatic Flowrate Management	Yes	Yes	Yes	Yes	Yes	Yes	Yes	Yes
Ultraviolet Intensity Sensor	Optional	Optional	Optional	Optional	Optional	Optional	Optional	Optional
Automated Flush System	Recommended	Recommended	Recommended	Recommended	Recommended	Recommended	Recommended	Recommended
Automated Lamp-Out Alarm	Yes	Yes	Yes	Yes	Yes	Yes	Yes	Yes
Automated Lamp-Out Switch-Over	Optional	Yes	Yes	Yes	Yes	Yes	Yes	Yes
Valve & Flow Meter Monitoring	Yes	Yes	Yes	Yes	Yes	Yes	Yes	Yes
Lamp Life-Time Hours	Yes	Yes	Yes	Yes	Yes	Yes	Yes	Yes
Lamp/status indicator LED	Yes	Yes	Yes	Yes	Yes	Yes	Yes	Yes
Safety cut out switch	Yes	Yes	Yes	Yes	Yes	Yes	Yes	Yes
Stainless Steel inlets and outlet	Yes	Yes	Yes	Yes	Yes	Yes	Yes	Yes
User interface touch screen	Optional	Optional	Optional	Optional	Yes	Yes	Yes	Yes
Control System	Embedded PC	Embedded PC	Embedded PC	Embedded PC	PLC	PLC	PLC	PLC
4G SIM Remote Monitoring	Yes	Yes	Yes	Yes	Yes	Yes	Yes	Yes
Continuous Monitoring Camera	Optional	Optional	Optional	Optional	Optional	Optional	Optional	Optional
Containerised Housing	Optional	Optional	Optional	Optional	Optional	Optional	Optional	Optional
Air Conditioning Unit	As Required	As Required	As Required	As Required	As Required	As Required	As Required	As Required
<b>Operating Requirements</b>								
Power Supply Requirements	1-PH, 10A	1-PH, 16A	3-PH, 20A	3-PH, 20A	3-PH, 32A	3-PH, 32A	3-PH, 32A	3-PH, 32A
	Excludes power allowance for air-conditioning				Includes power allowance for air-conditioning			
Max. Operating Pressure (Bar)	7.5 Bar	7.5 Bar	7.5 Bar	7.5 Bar	7.5 Bar	7.5 Bar	7.5 Bar	7.5 Bar
Min. Operating Pressure (Bar)	0.5 Bar	0.5 Bar	0.5 Bar	1 Bar	1 Bar	1 Bar	1 Bar	1 Bar
Max. Particulate Size (micron)*	1000	1000	1000	1000	1000	1000	1000	1000
pH Range	**	**	**	**	**	**	**	**
Max. Liquid Viscosity	***	***	***	***	***	***	***	***

\* larger particle throughput possible on request (subject to treatment goals)

\*\* Contact *NovoLabs™* to discuss liquids that are not neutral

\*\*\* Contact *NovoLabs™* to discuss any highly viscous liquids requiring treatment